

**metos**  
cooking solutions

***Metos Proveno is a smart solution  
for easy and economical food production***



[metos.com](http://metos.com)

# Metos Proveno Combi Kettle

*Metos Proveno is approachable and intuitive loaded with smart functions*



Guided touchscreen with clear symbols.

Various phases are displayed on the status display. Audible signals inform the user about any required actions.

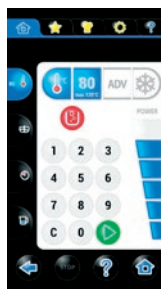

Standard temperature and output settings.

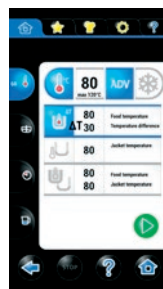

ADVANCED control according to exact temperature of both the food and the kettle jacket as well as the temperature difference of the two.



Ready-to-use mixing patterns for various types of mixing.

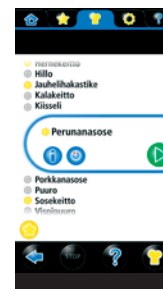

Ready-to-use programmes for standard dishes. Recipe windows and audible prompting signals.

# Metos Proveno Combi Kettle

Strong, maintenance-free, auto-reverse mixer for all mixing and whipping. Also available as a heavy-duty version for extra heavy loads in sizes 150 and 200. \*300-400 L kettles heavy duty mixer is standard.

Raised control panel is clearly visible, simple to use and protected from collisions.

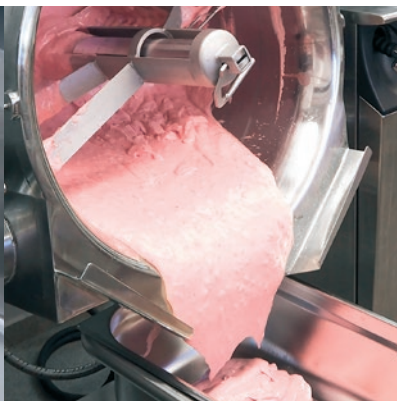

**All kettle sizes suitable for free standing installations.**

Food water inlet directly positioned for flow into the kettle, even when tilting.

Distance to floor is over 600 mm when kettle is fully tilted. High tilting kettle is fast and easy to empty. 600 mm high trolleys fit under the kettle pouring lip.

Reel-in handshower or other handshower models are optional.

# Touchscreen enables easy programming

Programming is now a standard feature in Proveno. An unlimited number of programmes with unlimited number of programme phases may be saved and read. Easy programming via kettle's touchscreen. The kettle has various standard programmes already installed which are easily edited and saved for your own use together with the necessary ingredient data. Additionally, it is easy to export kettle functions to programmes. You can create favourite pages for programmes and sort the pages according to subjects such as, for example, potato dishes.

**You can set all kettle functions to programmes**

## Tips

Ready to use programmes may be pre-set according to time and date, for example, for preparing porridge for Monday morning.

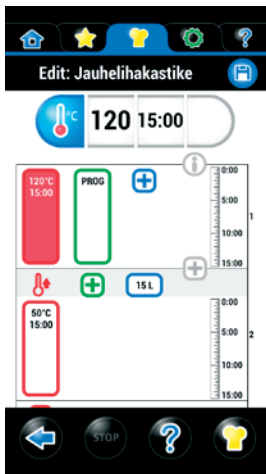

Pre-set starting of the programmes according to time and date.



Favourite pages for saving the most popular programmes according to, for example, the recipe's main ingredient.



Ingredients may be listed in the recipe windows.

# ***Proveno free standing installations including groups, steam kettle groups, ice bank kettles***

## ***All unique features***

- Free standing kettles can be group installed
- Steam heated kettles can be group installed
- Ice bank connected kettles can be group installed
- Installation flanges prevent kettle from moving but not lifting away when needed
- Proveno 4G and Viking 4G kettles can be mixed in groups



## ***Space saving group installations***

- even free standing kettle can be group installed saving space of another pillar
- Proveno 4G and Viking 4G kettles and Viking MixPan can be mixed in same groups
- no restrictions to kettle sizes, any size or order within the group

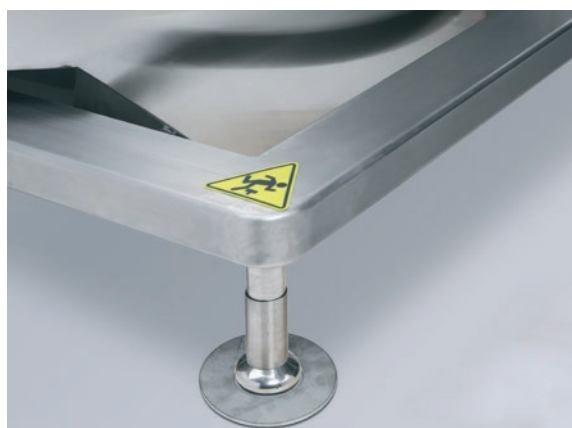

## ***Unique installation flanges***

- no holes in the floor materials
- allow kettle lifting away if needed

# ProTemp temperature control is based on real-time temperature



**Cooking in low temperature**  
**Sous vide**  
**Cold production**  
**Milk-based foods**  
**Mixing and proving of dough**  
**Desserts**  
**Tempering**

The ProTemp advanced temperature control helps you to prepare even the most demanding dishes effortlessly and prevent food from burning. You can set the temperature of the dish as well as the kettle jacket, or both. Delta-T cooking function helps to reduce loss and makes even the stringiest ingredients juicy by simmering them slowly for a long period of time.

The real-time temperature of the food and the kettle jacket is constantly displayed while cooking and cooling. All temperatures are saved and downloadable to USB sticks for inhouse monitoring purposes.

## Wireless temperature monitor for inhouse controlling

Metos SmartKitchen is a wireless, easy-to-use and quickly implemented temperature monitoring system which enables ensuring food safety and quality monitoring easily and efficiently. The Metos SmartKitchen sensors collect temperature data in real time, and transfers the data via Bluetooth to Android mobile phones or tablets. From the phone or tablet the data is further transferred to online service supporting all browsers. Metos SmartKitchen enables you to monitor the circumstances at various measuring points and locations online wherever you are. Human errors are eliminated in entering data and employees become available for more productive tasks.



- Inexpensive, and easy to install and use
- No software installations (cloud service)
- Transfers data to mobile phones and tablets
- Supports all browsers
- Daily, weekly and monthly reports
- Alarms

# Automatic cooling by Proveno is better and quicker than ever

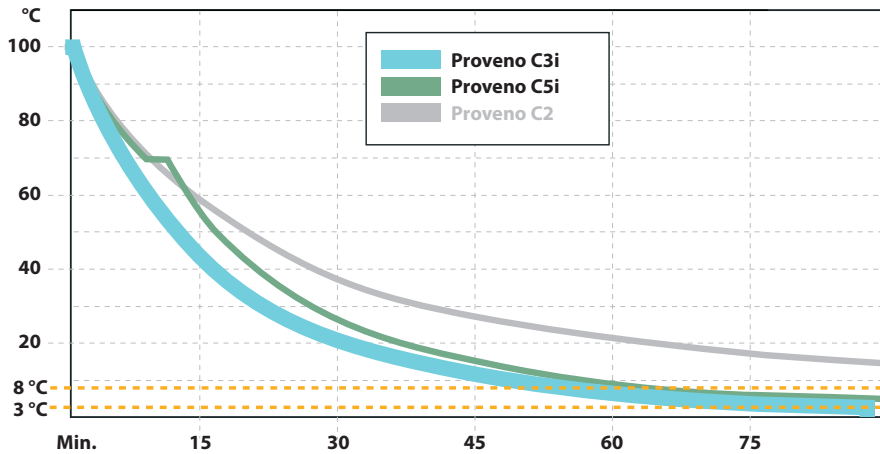

Automatic cooling: Set target food temperature and start – that's it! Automatic steam jacket drainage after cooling. Food temperature continuously on display. Cooling can be interrupted, stopped or target temperature changed during cooling. Automatic stop when the product is not cooled down further, safety functions to avoid unintentional cooling. Cool & Hold function keeps the food at set temperature. Cooling media can be tap water or ice water from separate ice water supply.

### Cooling with tap water\*

Automatic cooling with tap water C2 – open circulation  
Set target temperature and start – that's it.

### Cooling with ice bank\*

Automatic ice water cooling C3i – closed circulation  
Ice water circulates between the ice builder and the kettle's steam jacket (closed circulation). Drainage with pressurised air saves water in ice water circulation.

Automatic two-phase cooling C5i  
Cooling starts with tap water, when temperature difference is big and switches over to ice water cooling, when the difference has decreased. Ice water circulates between the ice builder and the kettle's steam jacket.

\* Kettle does not make water colder for cooling purposes. To achieve colder than tap water temperature kettle must be connected to an ice bank or fluid chiller.

## Cold production

Cold ingredients and kettle cooling on when preparing food reduces the need for cold rooms.

# Proveno's attention to details and accessories

**All lid parts are dishwasher proof**



Unique stainless steel lid. All parts are easily removable and dishwasher proof. A safety grid lid comes as standard.

**The lid can be rotated in up position if needed for cleaning**



Room for utensils and accessories on top of the kettle stand. Enough room a GN 1/1 pan!

**Automatic filling with water**



Automatic filling with water: adjustable and by-pass to drain prior to filling up for "the first water" from the tap if you do not want to use it for cooking. Automatic filling up with water and manual filling up via push button (litres displayed) - works also when the kettle is being tilted.

**Blender kit (option) and specialized handmixer**

## **Tips**

Rinse by tilting, for example pasta

Handmixer fits firmly to a connection on a special lid and a special mixer tool mixes simultaneously. The lid and the mixer tool for use with handmixer are suitable for all Metos 40-100 L kettles.

Cream soups safely. Incredibly smooth purees with blender kit.





# Proveno kettle is easy to clean



ProTemp food temperature control prevents food from burning to surfaces. Even milk based food does not stick or scorch. Kettle cleaning is extremely easy.

Glossy, polished surface is easy to clean with cleaning brush or cleaning tool.



Easily removable scrapers. All parts are machine washable.

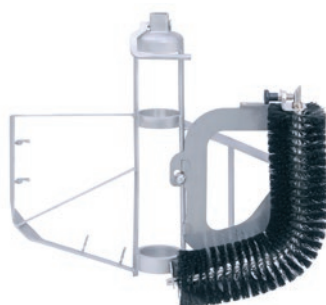

The kettle washing tool is attached to the standard mixer.



All lid parts and mixer tool parts can be washed in dishwasher.

## Tips

Always empty the kettle with the water pouring aid to keep the floor tidy and the floor drain unclogged. The water pouring aid is easy to clean, even in a dishwasher.



Ready-to-use washing programme. Individual washing programmes may be saved as necessary.



Plenty of hand shower options.

## Tips

Use cooling when washing the kettle: 4 minutes cooling and the kettle is cool enough for washing.

# Standard features

- Proveno kettle with integrated mixer
- Stepless mixing speed in all sizes 15-140 rpm/min, autoreverse
- Elevated control pillar with guiding touch panel
- Audiovisual signals for user
- Multi functional timer
- Programming on screen, unlimited number of programs and program phases, favourite pages
- Programs for basic foods and wash programs
- Mixing patterns and saving of your own patterns
- ProTemp – real time temperature control, food and jacket temperature separately controlled. Intelligent power setting from gentle warming to full power. Allows for example low temperature cooking, sous vide, proving and tempering.
- Delta T cooking – temperature of jacket rises accordingly when food temperature rises, temperature difference is determined.
- User privilege levels
- Automatic measured water filling
- Electric tilting 40-150 L kettles, hydraulic tilting 200-400 L kettles
- Tilting while mixing function
- Auto tilt-back
- USB Port on control panel for program updates, program transfers and HACCP data saving
- Teacher status for training
- Phone app for training
- Diagnostics for maintenance
- On screen energy and water consumption measuring
- Steam jacket automatic fill
- Rotating lid in up position
- Measuring stick



Metos Proveno 100 L free standing



Metos Proveno FS 400 L free standing

150, 200 and 300 L kettles are optionally available with more powerful heating.

Metos Proveno ELECTRIC	Code	Dimensions mm	Electric connection
Metos Proveno 40E	4224300	1047x720x900/1535*	400V 3N- 12,5 kW 25A
Metos Proveno 60E	4224302	1047x720x900/1535*	400V 3N- 18,0 kW 32A
Metos Proveno 80E	4224304	1154x720x900/1535*	400V 3N- 22,0 kW 40A
Metos Proveno 100E	4224306	1154x720x900/1535*	400V 3N- 22,0 kW 40A
Metos Proveno 150E	4224308	1360x920x900/1535*	400V 3N- 27,6 kW 50A
Option extra power 150EH	4222992		400V 3N- 35,6 kW 63A
Metos Proveno 200E	4224310	1360x920x900/1535*	400V 3N- 35,6 kW 63A
Option extra power 200EH	4222992		400V 3N- 46,5 kW 80A
Metos Proveno 300E	4224312	1560x1100x900/1535*	400V 3N- 47,6 kW 80A
Option extra power 300EH	4222992		400V 3N- 60,8 kW 100A
Metos Proveno 400E	4224314	1560x1100x1050/1535*	400V 3N- 62,0 kW 100A

Also steam heated models.

\*control pillar/control panel



Free standing frame

**Free standing frames**

# Dimensions

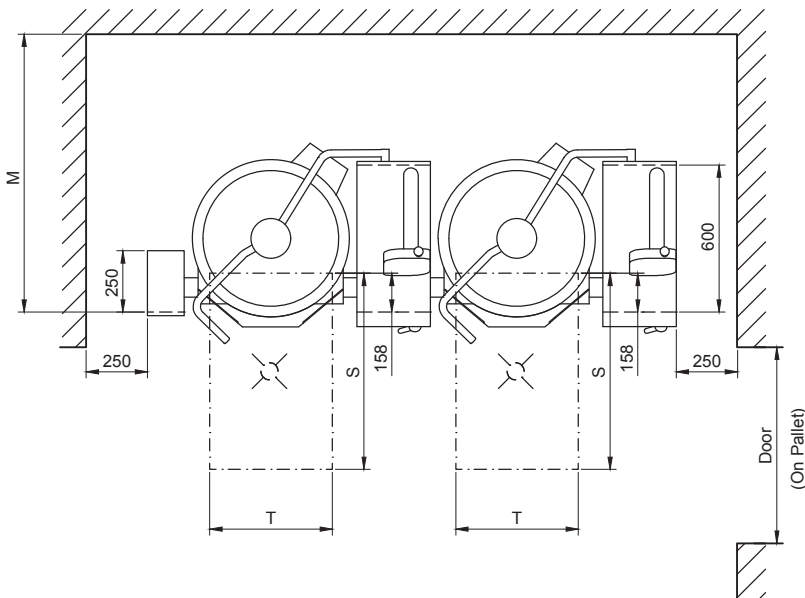
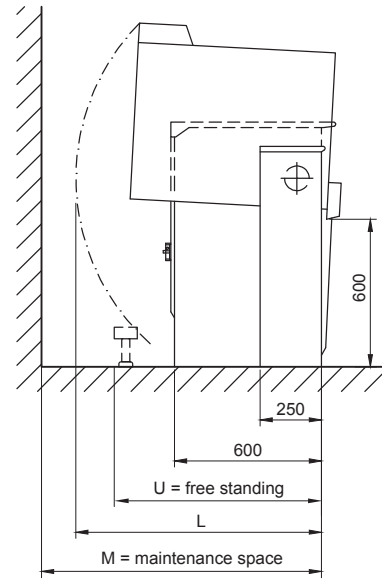
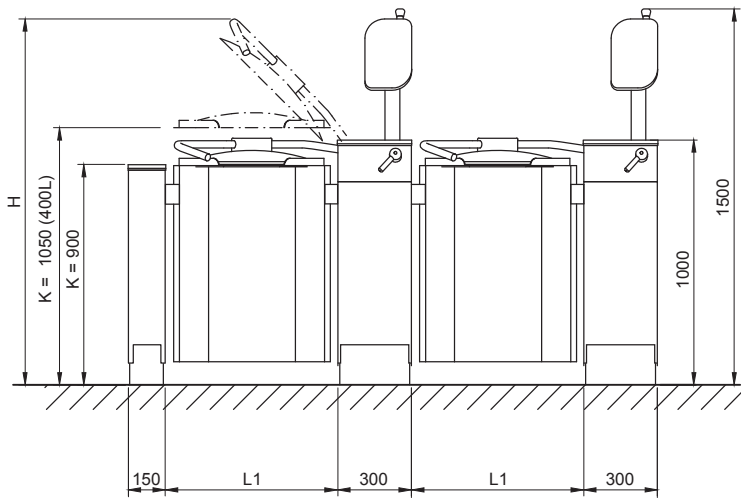

Proveno	L1 (mm)	H (mm)	K (mm)	L (mm)	M (mm)	S (mm)	T (mm)	U (mm)	( On Pallet ) Size varies according to installation frame	Weight (kg)
40	594	1740	900	870	1055	800	400	860	(900-1100)	200
60	594	1740	900	955	1180	800	400	860	(900-1100)	210
80	704	1745	900	1010	1235	800	500	890	(900-1100)	230
100	704	1745	900	1010	1235	800	500	890	(900-1100)	265
150	910	1945	900	1075	1170	800	600	1110	(1100-1300)	305
200	910	1945	900	1155	1285	800	600	1110	(1100-1300)	345
300	1110	2110	900	1280	1320	1000	600	1010	(1300)	415
400	1110	2080	1050	1280	1320	1200	600	1010	(1300)	475

National and local regulations must be observed when installing the kettle.

## Installation options

Single kettle  
Kettle group

Sub surface  
installation



Surface  
installation



Free standing  
installation



Installation  
flanges



Mid floor railing

Kit1

Kit2



# Metos Proveno

Installation frame kits	Code
Install frame surface 4G	4224000
Install frame sub surface 4G	4224002
Install frame group, surface 4G	4224004
Install frame group, sub-surface 4G	4224006
Free standing frame 40-60 4G	4224008
Free standing frame 80-100 4G	4224009
Free standing frame 150-200 4G	4224010
Free standing frame 300-400 4G	4224011
Free standing group frame 40-60 4G	4224012
Free standing group frame 80-100 4G	4224013
Free standing group frame 150-200 4G	4224014
Free standing group frame 300-400 4G	4224015
Free standing flanges 4G	4224020
Free standing mid floor 1 4G	4224016
Free standing mid floor 2 4G	4224018

Installed at the factory	Code
Cooling C2 auto tap water open circuit	4222950
Cooling C3i, ice water, closed circuit	4222952
Cooling C5i, 2-phase open+closed circuit	4222954
Cooling C3i PA ice water, closed circuit + pressure air*	4222956
Cooling C5i PA 2-phase open + closed circuit + pressure air*	4222958
Double water connection	4212292
Welded seamless insulated cover plates 4G	4224022
Handshower standard S1 4G	4222966
Handshower heavy duty S2 4G	4222964
Handshower reel-in S3 4G	4222962
Temperature sensor Metos SmartKitchen	4008006
Draw off valve D1-std 40 mm	4211972
Draw off valve connection D2-B/AUS SMS63 80-400L delivered plugged	4222135
Arc valve CIP D2 SMS63 TC/ SMS51 male end	4222747
Butterfly valve D2 SMS63 TC	4222763
Adapter for pump hose D2 SMS63 TC/ SMS51 male end	4222764
Foot pedal mixing tilting Metos Proveno 4G	4222960
Mix tool factory option 150 Heavy duty**	4215822
Mix tool factory option 200 Heavy duty**	4215719
High performance heating Proveno 150-300 *requires additional kW supply	4222992
Socket outlet 230V 16A behind control panel	4224026
Work light	4224040



Foot switch for mixing when tilting releases hands.

\*Drainage with pressurised air saves water in ice water circulation.  
\*\*300-400 litre kettles come with Heavy Duty mixer as standard.



Handshower standard S1 4G



Handshower heavy duty S2 4G



Handshower reel-in S3 4G



Draw off valve D1-std 40 mm



Work light



Draw off valve connection D2-B/AUS SMS63 TC (delivered plugged)



Arc valve CIP D2 SMS63 TC/ SMS51 male end



Three way arc valve



Arc valve and plug



Butterfly valve D2 SMS63 TC



Adapter for pump hose D2 SMS63 TC/ SMS51 male end



Socket outlet in control panel

# Assembly recommendations

## **Cook-serve**

- kettle
- cooling C2
- strainer plate
- whipping grid
- hand shower
- wash tool
- SmartKitchen HACCP-anturi
- blender kit 40-100 L
- DiagoMix-kit
- foot pedal

## **Cook-chill**

- kettle
- cooling C3i +pressurised air drainage
- ice bank
- strainer plate
- whipping grid
- hand shower
- wash tool
- SmartKitchen HACCP-anturi
- blender kit 40-100 L
- DiagoMix-kit
- foot pedal

## **Hot-fill**

- kettle
- draw off valve connection D2AUS
- kaariventiili + tulppa
- cooling C2
- strainer plate
- whipping grid
- hand shower
- wash tool
- SmartKitchen HACCP-anturi
- accessory trolley AT-77
- blender kit 40-100 L
- DiagoMix-kit
- foot pedal

## **Coming soon: Sous-vide-kettle**

## **Cold production**

- kettle
- draw off valve connection D2AUS
- arc valve + plug system
- cooling C3i +pressurised air drainage
- ice bank
- chilled food water
- strainer plate
- whipping grid
- hand shower
- wash tool
- SmartKitchen HACCP-anturi
- accessory trolley AT-77
- blender kit 40-100 L
- DiagoMix-kit
- foot pedal

## **Automatic dosing**

- kettle
- draw off valve connection D2AUS
- arc valve
- plug system
- dosing system DOS-1-2 tai 3
- accessory trolley AT-77

## **Non-Stop-dosing for 2 kettles**

- 2 kettles
- draw off valve connection D2AUS in both kettles
- arc valve
- Non-Stop-valve
- 2x plug system
- dosing system DOS-2 or 3
- extra suction hose for DOS

# Metos kettle accessories

Accessories	Code
Strainer plate 40-60	4222196
Strainer plate 80-100	4222198
Strainer plate 150-200	4222200
Strainer plate 300-400	4222202
Strainer plate extension 300-400	4222204
Pouring adapter 150-200	4222206
Pouring adapter 300-400	4222208
Whipping grid 40-60	4211203
Whipping grid 80-100	4211193
Whipping grid 150-200	4211186
Whipping grid 300	4211179
Whipping grid 400	4215872

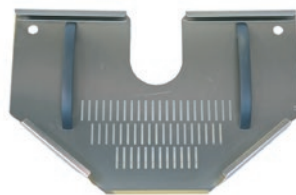

Strainer plate

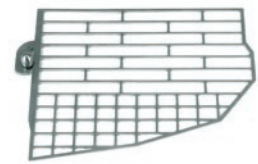

Whipping grid

DiagoMix-kit	Code
DiagoMix-kit 40 - 60 L	4215822
DiagoMix-kit 80 - 100 L	4215719
DiagoMix-kit 150 - 200 L	4215721
DiagoMix-kit 300 - 400 L	4215868

Includes DiagoMix lid and attachment to the mixer tool.



Pouring adapter

**A comprehensive selection of accessories for ergonomic and functional production**

Heavy Duty Mixing tool retrofit	Code
Heavy Duty Mixing tool 150 L	4215822
Heavy Duty Mixing tool 200 L	4215719
Heavy Duty Mixing tool 300 L	4215721
Heavy Duty Mixing tool 400 L	4215868



DiagoMix kit



Cleaning brush

Kettle cleaning	Code
Cleaning tool 60 L	4222728
Cleaning tool 80 L	4222729
Cleaning tool 100 L	4222730
Cleaning tool 150 L	4222731
Cleaning tool 200 L	4222732
Cleaning tool 300 L	4222733
Cleaning tool 400 L	4222734
Cleaning brush	4222791
Scraper	4222790



Heavy duty tool



Pouring support

Accessories	Code
Potato stick Soft 670	4000031
Pouring support	4000012
Hot fill bag support	4222727
Pouring support 80/100 for GN containers, swinging	4224050
Pouring support 150/200 for GN containers, swinging	4224052
Pouring support 300/400 for GN containers, swinging	4224054

Sous Vide	Capacity	Code
Sous Vide Kit Proveno 80 L	35 kg	4222723
Sous Vide Kit Proveno 100 L	35 kg	4222724
Sous Vide Kit Proveno 150 L	60 kg	4222725
Sous Vide Kit Proveno 200 L	60 kg	4222726

Blender kit	Code
Blender kit for Proveno 40 L	4222735
Blender kit for Proveno 60 L	4222736
Blender kit for Proveno 80 L	4222737
Blender kit for Proveno 100 L	4222738

Includes blender lid, special mixing tool and blender MF2000 Combi

Trolleys	Code
Multipurpose trolley MPT-450, GN1/1	4554354
Mixer tool holder to MPT-450 trolley	4215990
Draining aid to MPT-450 trolley	4000009
Multipurpose trolley MPT-2/450, GN2/1	4554355
Kettle accessory trolley KTT	4554564
Kettle accessory trolley AT-77	4554586



Cleaning tool is attached to the mixing tool



Swinging pouring support

Accessories	Code
Measurement stick 40	4222212
Measurement stick 60	4222214
Measurement stick 80	4222216
Measurement stick 100	4222218
Measurement stick 150	4222220
Measurement stick 200	4222222
Measurement stick 300	4222224
Measurement stick 400	4222226

# Metos kettle accessories



Potato stick



Measurement stick



Hot fill bag support



Sous Vide basket and Sous Vide tool



Blender top kit

*With the help of accessory trolleys you make working more fluent*



Multipurpose trolley MPT-450



Draining aid for MPT-450



Mixer tool holder for MPT-450 trolley



Multipurpose trolley MPT-2/450



Kettle accessory trolley KTT



Kettle accessory trolley AT-77

# **BGL** *Rieber*

**BGL RIEBER LTD**

Unit 1, Lincoln Industrial Estate

Avro Business Centre, Avro Way, Bowerhill, Melksham SN12 6TP. UK

tel. +44 (0) 1225 704470

e-mail: [sales@bglrieber.co.uk](mailto:sales@bglrieber.co.uk)    [www.bglrieber.co.uk](http://www.bglrieber.co.uk)

CE



**metos**  
kitchen intelligence®